

Thunder CFW

Consolidated Firewall, CGN, ADC, VPN and Secure Web Gateway

A10 Thunder® Convergent Firewall (CFW) is a high performance consolidated security solution for service providers, cloud providers and large enterprises that includes integrated application delivery and security solutions in a single, standalone product.

High-performance Security

Modern service providers, web giants, enterprises and cloud platform providers aim to defend global networks, ensure high availability and low latency, secure infrastructure, encrypt data and protect customers.

A high-performance, all-inclusive security product, A10 Thunder Convergent Firewall (CFW) is a cost-effective approach for strengthening security postures and protecting network perimeters without the need for disparate point products.

A10 Thunder CFW features a carrier-class firewall for mobile infrastructure security, carrier-grade networking, secure application delivery, data center firewall, DNS security, IPsec VPN, and secure web gateway for enterprises, mobile network operators and other service providers.

Thunder CFW includes all Thunder ADC, CGN and SSLi features.

Thunder CFW is built on A10's market-proven ACOS® platform that delivers scalable form factors and cost structures that make economic sense. Offering unmatched performance and scalability with the industry's best data center footprint for integrated security and application networking needs, Thunder CFW reduces an organization's total cost of ownership (TCO).

Platforms



Physical Appliance



Virtual Appliance



Container

Management



Harmony Controller
Centralized Analytics and
Management



Flexpool
Capacity Pooling
License



Carrier-class Firewall

Protect subscribers and shield mobile core infrastructure from cyber attacks and signaling storms at the Gi/SGi, GTP/roaming and RAN to ensure uninterrupted operations. Built on A10's proven Thunder CGN technology, the firewall combines the security of a carrier-grade firewall with integrated DDoS protection features to serve as a carrier-grade networking solution for mobile network operators.



Secure Web Gateway

Eliminate the SSL blind spot in corporate defenses, restrict access to undesirable websites, and identify malicious traffic with our secure web gateway. This feature combines A10's SSL Insight® technology, URL filtering, and a multi-layered security approach to protect users from modern, encrypted cyberthreats.



Data Center Firewall

Unite application delivery control and security on a single platform to reduce hardware and operating costs. The high-performance data center firewall includes a Layer 4 firewall with integrated DDoS protection and advanced server load-balancing to protect data center assets from the inside out. It also includes DNS security features to secure and consolidate DNS infrastructure.



IPsec VPN

Encrypt data at a massive scale – including in the cloud – with this high-speed, site-to-site IPsec VPN designed for enterprises and service providers. In mobile networks, it can be deployed as a security gateway to enable secure backhaul between the RAN nodes and the core network.

The policy-based IPsec VPN also enables high-capacity client-to-site VPN deployment to support remote access clients in enterprise network.

CERTIFICATIONS



[SEE ALL CERTIFICATIONS](#)

Features and Benefits

Designed for enterprises, service providers and mobile network operators, A10 Thunder CFW offers the performance and versatility needed to safeguard applications, users and infrastructure.



Comprehensive Mobile Core Protection

Granular control over network resources allows mobile network operators to block network and DDoS attacks that may arise from a variety of intrusion points at the Gi/SGi, GTP/roaming and RAN in 3G-4G, 5G SA, 5G NSA and MEC architectures. Thunder CFW offers Gi LAN services consolidation to combine L4-L7 functions, including CGNAT, stateful firewall, and application-aware firewall and visibility to integrate greater efficiencies on the Gi LAN. It protects subscribers and shields 3G/4G data and control plane services, including the Gateway GPRS Support Node (GGSN) and Packet Gateway (PGW) in the Evolved Packet Core (EPC), from a wide array of threats. It also defends the mobile core against GTP-based attacks coming in from access networks and roaming partners to support uninterrupted operations. Thunder CFW can secure its own resources, such as NAT IP pools, to ensure that operational functions are not compromised.

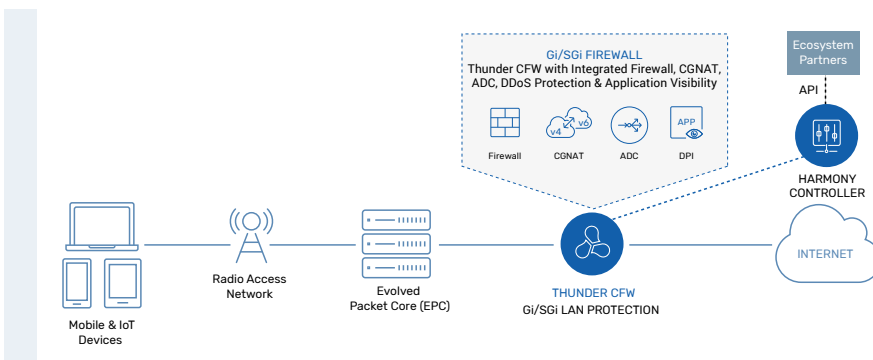

A10 Gi/SGi Firewall for the GiLAN

In this scenario, a mobile network operator deploys the Gi/SGi firewall to secure communication between the EPC and the internet to protect the mobile core infrastructure. Integrated carrier-grade NAT enables carriers to manage communication with both IPv4 and IPv6 address protocols. Built-in DDoS protection safeguards the NAT IP pools to avoid service interruption. A10 Harmony® Controller provides centralized management and analytics.

IPv4 Preservation and IPv6 Transition

Integrated carrier-grade networking functionality includes CGNAT to preserve investments in existing IPv4-based infrastructure and comprehensive IPv6 transition options to facilitate a smooth transition to IPv6. This ensures seamless subscriber experiences and sustainable subscriber growth. Integrated application layer gateways (ALGs) ensure that applications remain addressable and operate transparently through address translation.

Granular Visibility and Reporting

DPI-based application visibility with comprehensive subscriber awareness provides granular insights into network traffic. Understanding network and application traffic trends allows for effective network planning, deeper business intelligence, tighter security controls, enhanced law enforcement agency compliance and service monetization.

High-performance, Scalable Firewall

Thunder CFW carrier-class firewall enables mobile network operators to achieve exceptionally high firewall connection rates, throughput, and higher NAT session capacity to meet service providers' current and future traffic requirements. Simplify operational tasks and reduce CAPEX and OPEX by integrating CGNAT, stateful firewall, and DDoS protection capabilities.

Agile Management and Analytics-driven

Gain application and network services visibility with the A10 Harmony Controller for Thunder CFW. Centrally configure and manage policies across services in a multi-cloud environment. Get customizable drill-down views for analysis and actionable insights for faster troubleshooting.

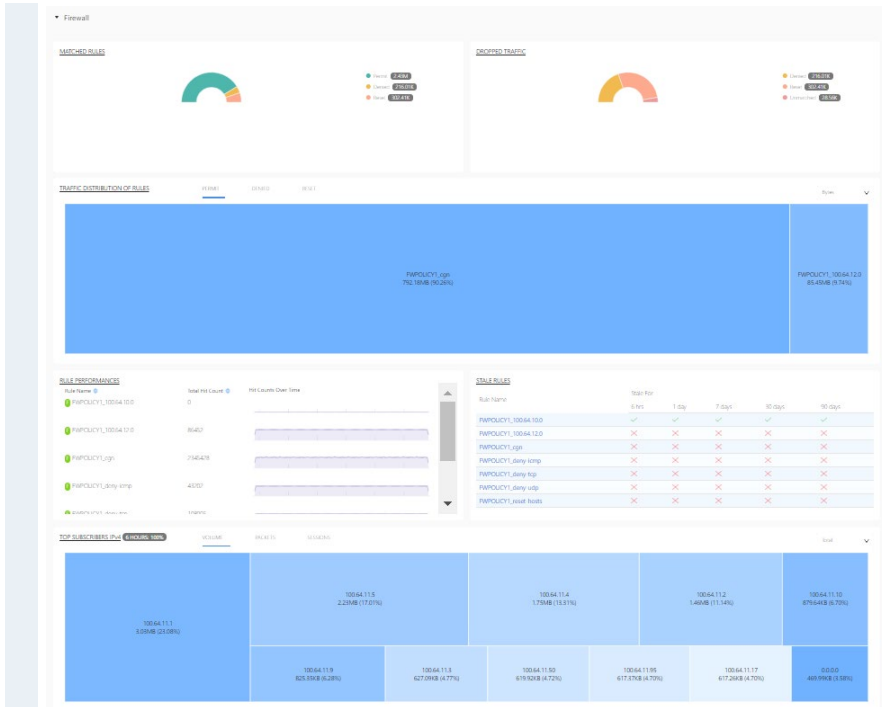

Agile Management and Analytics-driven Dashboard

Gain application and network services visibility with the A10Harmony Controller for Thunder CFW. Centrally configure and manage policies across services in a multi-cloud environment. Get real-time actionable insights on firewall performance, critical CGN services such as mapping distribution, NAT IP pool utilization and more, and application visibility including application distribution by category, bytes consumed by application category.



Secure Web Gateway

Decrypt Once, Inspect Multiple Times

Leverage A10's SSL Insight technology to decrypt SSL traffic and forward it to third-party security devices for inspection. Maximize uptime and increase security infrastructure capacity with integrated load balancing. Unburden firewalls and other security devices from computationally intensive SSL decryption, enabling them to detect and stop attacks.

Gain Superior Control with URL Filtering

Maximize employee productivity and reduce risks by blocking access to malicious websites, including malware, spam and phishing sources. The A10 URL Classification categorizes more than 460 million domains and 13 billion URLs into 83 categories to block undesirable sites and shield users from threats.

Block Known Web Threats

Identify and block traffic going out to and coming in from known bad IP addresses on the internet with threat intelligence feeds.

Prevent Data Exfiltration

Integrate with third-party Data Loss Prevention (DLP) solutions via the industry-standard ICAP. Send decrypted traffic to DLP servers for inspection before forwarding intercepted traffic to a client or a server.

Enforce Authentication and User-based Policies

Create security policies for users, making sure no unauthorized access is allowed, with the identity and access management feature. This also enables you to define user-ID-based traffic and inspection policies to maintain granular control.

Ensure Compliance

Leverage the SWG's high-speed logging capabilities to keep track of all session activities, per-rule statistics for SIEM integration, and authenticated session logging.

Gain Superior Visibility and Control into Application Traffic

Identify and categorize traffic on the application level, allowing for more granular controls and policies to be defined, with application visibility and control. This DPI-based service provides application visibility with comprehensive user and group awareness, providing deep insights into network traffic. Understanding application traffic trends in enterprise networks allows for effective security planning and sanctioning of allowed business applications.

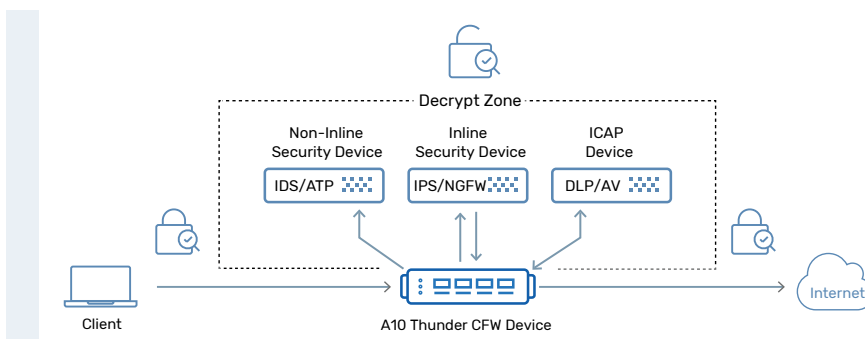

Secure Web Gateway Protects the Enterprise Perimeter

Deploy Thunder CFW, with integrated SSL Insight technology, to decrypt traffic for a variety of security products, including inline, non-inline (passive/TAP) and ICAP-enabled devices.



Data Center Firewall

Achieve Unprecedented Firewall Performance

Powered by A10's Advanced Core Operating System (ACOS®), Thunder CFW provides high performance in a compact appliance, allowing organizations to stop emerging threats at scale.

The Thunder CFW data center firewall offers exceptionally high firewall connection rates – 370 Gbps of throughput – in a 1.5 rack-unit appliance that provides enough capacity to support up to 768 million concurrent sessions. Eliminate traditional performance bottlenecks while protecting your data center assets.

Secure and Simplify DNS Infrastructure

Improve security and performance of DNS infrastructure by consolidating multiple DNS security solutions such as DNS load balancing, DNS firewall (RPZ), DNS over HTTPS (DoH)/DNS over TLS (DoT), DNSSEC and DNS caching.

Consolidate Application Delivery and Security

Eliminate single-purpose devices from data centers by consolidating security and application delivery controller (ADC) features on one platform to reduce hardware and operating costs. Optimize the delivery and security for potentially hundreds of apps in a given data center.

Protect Multi-tenant Environments

Leverage the A10 Harmony Controller architecture to deliver completely programmable security for the data center. A10 Harmony Controller unifies policy control across multiple clouds, offering unprecedented telemetry as well as 100 percent RESTful API coverage. The product supports multi-tenancy features like application delivery partitions (ADP) for segmentation.

Thunder 7650 CFW

by the Numbers

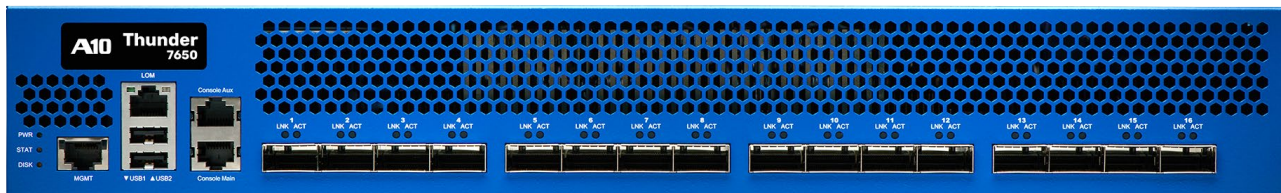
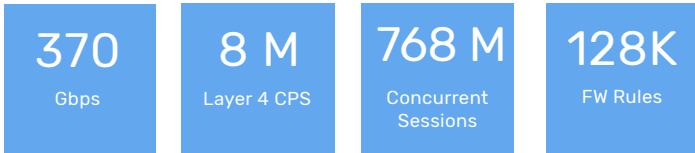



Encrypt Data at Unparalleled Speeds

Securely interconnect remote sites over the internet using high capacity and massive scale IPsec VPN. Thunder CFW features a broad array of encryption algorithms and data integrity methods for securing communications in mobile networks and/or between hybrid cloud workloads.

Select Thunder CFW platform provides hardware-based IPsec cryptographic security, supporting unprecedented IPsec throughput levels and large number of IPsec VPN tunnels.

Consolidate IPsec VPN, Firewall and Application Delivery

Thunder CFW unifies firewall and IPsec VPN capabilities on a single platform to improve agility through consolidation. Whether used to support secure interconnection between data centers, high speed VPN connections in the cloud, or secure connection between mobile network RAN nodes and core, Thunder CFW provides a comprehensive networking and security platform that reduces data center footprints and operating costs.

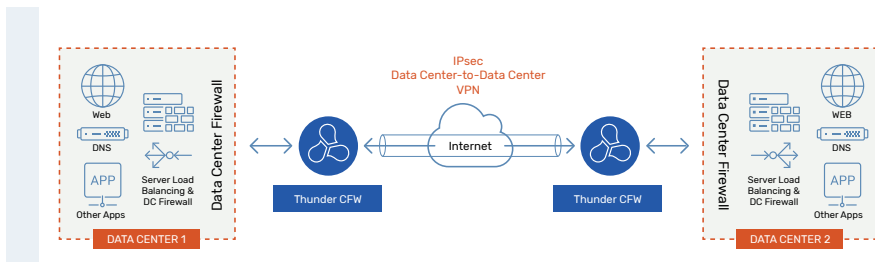

Data Center Firewall and IPsec VPN

By unifying IPsec VPN, firewall and application delivery controller (ADC) capabilities, organizations are able to both load-balance traffic and protect the data center, services and related applications from DDoS attacks and other threats.

Flexible Deployment Options

Thunder CFW provides industry-leading high performance as a physical, virtual or containerized solution. The physical appliance with hardware acceleration supports scalable and high-performance on-premises deployments. For NFVi and private cloud deployments, the virtual appliance works with leading hypervisors such as VMware ESXi, KVM and Microsoft Hyper-V, and integrates with leading NFV-MANO solutions including Ericsson Cloud Manager, NEC Netcracker HOM, Cisco NSO and Red Hat OpenStack and

more. For flexible and efficient cloud native deployments such as Docker and Kubernetes, the container option can be used.

All Thunder CFW options run on A10's ACOS software, providing feature parity, regardless of form factor, which helps simplify and consolidate operations in any deployment environment.

Thunder CFW Physical Appliance Specifications

	Thunder 1060S _{CFW}		Thunder 3350-E _{CFW}
Modular License	10 Gbps	25 Gbps	-
Firewall Performance			
Throughput	10 Gbps	25 Gbps	30 Gbps
Layer 4 CPS	300K	700K	550K
Concurrent Sessions	32 Million	96 Million	32 Million
FW Rules	16K	32K	16K
Secure Web Gateway Performance^{1,2}			
SSLi Throughput	1 Gbps	2 Gbps	3 Gbps
SSLi CPS	RSA: 2K ECDHE: 1.2K	RSA: 6K ECDHE: 4K	RSA: 8K ECDHE: 4.5K
IPsec VPN Performance²			
IPsec Throughput	10 Gbps	15 Gbps	10 Gbps
IPsec Tunnels	5K	10K	5K
IKE Gateways	5K	10K	5K
Network Interfaces			
1GE Copper	7	7	6
1GE Fiber (SFP)	0	0	2
10/1GE Fiber (SFP+/SFP)	4	4	8 + 4 ⁵
25/10GE Fiber (SFP28/SFP+)	2	2	0
40GE Fiber (QSFP+)	0	0	0
100/40GE Fiber (QSFP28/QSFP+)	0	0	0
Management Ports	Ethernet mgmt. port, RJ-45 console port		
Hardware Specifications			
Processor	Intel communications processor 20-core [9-core active]	Intel communications processor 20-core	Intel Xeon 8-core
Memory (ECC RAM)	32 GB [24 GB active]	32 GB	16 GB
Storage	SSD	SSD	SSD
Hardware Acceleration	Software	Software	Software
TLS/SSL Security Acceleration	Hardware	Hardware	Hardware
Dimensions (inches)	1.75 (H) x 17.5 (W) x 17(D)	1.75 (H) x 17.5 (W) x 17(D)	1.75 (H) x 17.5 (W) x 18(D)
Rack Units (mountable)	1U	1U	1U
Unit Weight	12 lbs	12 lbs	18 lbs
Power Supply (DC option available)	Dual 300W RPS	Dual 300W RPS	Dual 750W RPS
	80 Plus Platinum Efficiency, 100 - 240 VAC, 50 - 60 Hz		
Power Consumption (typical/max) ³	112W / 127W	112W / 127W	151W / 205W
Heat in BTU/hour (typical/max) ³	383 / 434	383 / 434	516 / 700
Cooling Fan (front-to-back airflow)	Removable fans	Removable fans	Hot swap smart fans
Operating Ranges	Temperature 0° - 40° C Humidity 5% - 95%		
Regulatory Certifications	FCC Class A, UL [*] , ICES, CE, UKCA, CB [*] , VCCI, BSMI [*] , RCM RoHS [*]	FCC Class A, UL [*] , ICES, CE, UKCA, CB [*] , VCCI, BSMI [*] , RCM RoHS [*]	FCC Class A, UL, CE, UKCA, CB, VCCI, BSMI, RCM RoHS
Standard Warranty	90-day hardware and software		

Thunder CFW Physical Appliance Specifications (cont.)

	Thunder 3350 CFW	Thunder 3350S CFW	Thunder 4440 CFW	Thunder 5440 CFW
Modular License	-	50 Gbps	-	-
Firewall Performance				
Throughput	40 Gbps	50 Gbps	70 Gbps	90 Gbps
Layer 4 CPS	750K	1.4 Million	1.5 Million	2 Million
Concurrent Sessions	40 Million	64 Million	64 Million	128 Million
FW Rules	32K	64K	32K	64K
Secure Web Gateway Performance^{*1*2}				
SSLi Throughput	3 Gbps	5.5 Gbps	8 Gbps	15 Gbps
SSLi CPS	RSA: 8K ECDHE: 4.5K	RSA: 20K ECDHE: 10K	RSA: 22K ECDHE: 10K	RSA: 35K ECDHE: 20K
IPsec VPN Performance^{*2}				
IPsec Throughput	15 Gbps	24 Gbps	30 Gbps	35 Gbps
IPsec Tunnels	10K	20K	10K	20K
IKE Gateways	10K	20K	10K	20K
Network Interfaces				
1GE Copper	6	6	0	0
1GE Fiber (SFP)	2	2	0	0
10/1GE Fiber (SFP+/SFP)	4 ⁵	8 + 4 ⁵	24	24
25/10GE Fiber (SFP28/SFP+)	4	0	0	0
40GE Fiber (QSFP+)	4	0	4	4
100/40GE Fiber (QSFP28/QSFP+)	0	0	0	0
Management Ports	Ethernet mgmt. port, RJ-45 console port		Ethernet mgmt. port, RJ-45 console port, Lights out management	
Hardware Specifications				
Processor	Intel Xeon 8-core	Intel Xeon 14-core	Intel Xeon 6-core	Intel Xeon 12-core
Memory (ECC RAM)	32 GB	64 GB	32 GB	64 GB
Storage	SSD	SSD	SSD	SSD
Hardware Acceleration	Software	Software	2 x FTA-4	2 x FTA-4
TLS/SSL Security Acceleration	Hardware	Hardware	Hardware on S model	Hardware on S model
Dimensions (inches)	1.75 (H) x 17.5 (W) x 18(D)	1.75 (H) x 17.5 (W) x 18(D)	1.75 (H) x 17.5 (W) x 30 (D)	1.75 (H) x 17.5 (W) x 30 (D)
Rack Units (mountable)	1U	1U	1U	1U
Unit Weight	18 lbs	18 lbs	32.5 lbs	32.5 lbs
Power Supply (DC option available)	Dual 750W RPS	Dual 750W RPS	Dual 1100W RPS	Dual 1100W RPS
	80 Plus Platinum Efficiency, 100 - 240 VAC, 50 - 60 Hz			
Power Consumption (typical/max) ³	165W / 238W	175W / 222W	360W / 445W	360W / 445W
Heat in BTU/hour (typical/max) ³	564 / 831	598 / 758	1,229 / 1,519	1,229 / 1,519
Cooling Fan (front-to-back airflow)	Hot swap smart fans			
Operating Ranges	Temperature 0° - 40° C Humidity 5% - 95%			
Regulatory Certifications	FCC Class A, UL, CE, UKCA, CB, VCCI, KCC, BSMI, RCM RoHS	FCC Class A, UL, CE, UKCA, CB, VCCI, KCC, BSMI, RCM RoHS, FIPS 140-2*	FCC Class A, UL, CE, UKCA, CB, VCCI, KCC, BSMI, RCM RoHS	FCC Class A, UL, CE, UKCA, CB, VCCI, KCC, BSMI, RCM RoHS, FIPS 140-2*
Standard Warranty	90-day hardware and software			

Thunder CFW Physical Appliance Specifications (cont.)

	Thunder 5840 CFW	Thunder 5840-11 CFW	Thunder 5960 CFW	Thunder 6440 CFW
Modular License	-	-	100/200/300 Gbps	-
Firewall Performance				
Throughput	100 Gbps	100 Gbps	300 Gbps ¹⁰	150 Gbps
Layer 4 CPS	3 Million	3 Million	1.9 Million	3 Million
Concurrent Sessions	128 Million	128 Million	256 Million	256 Million
FW Rules	64K	64K / 128K ²	128K	128K
Secure Web Gateway Performance^{11,2}				
SSLi Throughput	20 Gbps	25 Gbps	- ⁹	22 Gbps
SSLi CPS	RSA: 50K ECDHE: 25K	RSA: 50K ECDHE: 28K	- ⁹	RSA: 40K ECDHE: 15K
IPsec VPN Performance²				
IPsec Throughput	50 Gbps	55 Gbps	- ⁹	65 Gbps
IPsec Tunnels	20K	20K / 64K ²	- ⁹	64K
IKE Gateways	20K	20K / 64K ²	- ⁹	64K
Network Interfaces				
1GE Copper	0	0	0	0
1GE Fiber (SFP)	0	0	0	0
10/1GE Fiber (SFP+/SFP)	24	48	0	48
25/10GE Fiber (SFP28/SFP+)	0	0	4	0
40GE Fiber (QSFP+)	4	0	0	4
100/40GE Fiber (QSFP28/QSFP+)	0	4	4	0
Management Ports	Ethernet mgmt. port, RJ-45 console port, Lights out management		Ethernet mgmt. port, RJ-45 console port	Ethernet mgmt. port, RJ-45 console port, Lights out management
Hardware Specifications				
Processor	Intel Xeon 18-core	Intel Xeon 18-core	Intel Xeon 36-core	2 x Intel Xeon 10-core
Memory (ECC RAM)	64 GB	64 GB / 128 GB ²	128 GB	128 GB
Storage	SSD	SSD	SSD	SSD
Hardware Acceleration	2 x FTA-4	2 x FTA-4	Software	3 x FTA-4
TLS/SSL Security Acceleration	Hardware on S model	Hardware on S model	Hardware	Hardware on S model
Dimensions (inches)	1.75 (H) x 17.5 (W) x 30 (D)	1.75 (H) x 17.5 (W) x 30 (D)	1.75 (H) x 17 (W) x 24 (D)	1.75 (H) x 17.5 (W) x 30 (D)
Rack Units (mountable)	1U	1U	1U	1U
Unit Weight	32.5 lbs	34.3 lbs	25.1 lbs	36 lbs
Power Supply (DC option available)	Dual 1100W RPS	Dual 1500W RPS	Dual 550W RPS	Dual 1100W RPS
	80 Plus Platinum Efficiency, 100 - 240 VAC, 50 - 60 Hz			
Power Consumption (typical/max) ¹³	375W / 470W	550W / 760W	361W / 451W	480W / 550W
Heat in BTU/hour (typical/max) ¹³	1,280 / 1,604	1,877 / 2,594	1,232 / 1,539	1,638 / 1,877
Cooling Fan (front-to-back airflow)	Hot swap smart fans			
Operating Ranges	Temperature 0° - 40° C Humidity 5% - 95%			
Regulatory Certifications	FCC Class A, UL, CE, UKCA, CB, VCCI, KCC, BSMI, RCM RoHS, FIPS 140-2 ⁺	FCC Class A, UL, CE, UKCA, CB, VCCI, BSMI, RCM RoHS	FCC Class A, UL, CE, UKCA, CB, VCCI, BSMI ⁺ , RCM RoHS	FCC Class A, UL, CE, UKCA, CB, VCCI, KCC, BSMI, RCM RoHS
Standard Warranty	90-day hardware and software			

Thunder CFW Physical Appliance Specifications (cont.)

	Thunder 7440 CFW	Thunder 7440-11 CFW	Thunder 7650 CFW
Modular License	-	-	-
Firewall Performance			
Throughput	220 Gbps	220 Gbps	370 Gbps
Layer 4 CPS	5 Million	5 Million	8 Million
Concurrent Sessions	256 Million	256 Million	768 Million ⁸
FW Rules	128K	128K	128K
Secure Web Gateway Performance^{1 2}			
SSLi Throughput	25 Gbps	25 Gbps	- ⁹
SSLi CPS	RSA: 45K ECDHE: 20K	RSA: 45K ECDHE: 20K	- ⁹
IPsec VPN Performance²			
IPsec Throughput	70 Gbps	70 Gbps	- ⁹
IPsec Tunnels	64K	64K	- ⁹
IKE Gateways	64K	64K	- ⁹
Network Interfaces			
1GE Copper	0	0	0
1GE Fiber (SFP)	0	0	0
10/1GE Fiber (SFP+/SFP)	48	48	0
25/10GE Fiber (SFP28/SFP+)	0	0	0
40GE Fiber (QSFP+)	4	0	0
100/40GE Fiber (QSFP28/QSFP+)	0	4	16
Management Ports	Ethernet mgmt. port, RJ-45 console port, Lights out management		
Hardware Specifications			
Processor	2 x Intel Xeon 18-core	2 x Intel Xeon 18-core	2 x Intel Xeon 24-core
Memory (ECC RAM)	128 GB	128 GB	192 GB
Storage	SSD	SSD	SSD
Hardware Acceleration	3 x FTA-4	3 x FTA-4	2 x FTA-5
TLS/SSL Security Acceleration	Hardware on S model	Hardware on S model	No
Dimensions (inches)	1.75 (H) x 17.5 (W) x 30 (D)	1.75 (H) x 17.5 (W) x 30 (D)	2.625 (H) x 17.5 (W) x 30 (D)
Rack Units (mountable)	1U	1U	1.5U
Unit Weight	35.7 lbs	35.7 lbs	41.5 lbs
Power Supply (DC option available)	Dual 1100W RPS	Dual 1500W RPS	Dual 1500W RPS
	80 Plus Platinum Efficiency, 100 - 240 VAC, 50 - 60 Hz		
Power Consumption (typical/max) ¹³	690W / 820W	784W / 950W	864W / 1,091W
Heat in BTU/hour (typical/max) ¹³	2,355 / 2,798	2,676 / 3,242	2,949 / 3,722
Cooling Fan (front-to-back airflow)	Hot swap smart fans		
Operating Ranges	Temperature 0° - 40° C Humidity 5% - 95%		
Regulatory Certifications	FCC Class A, UL, CE, UKCA, CB, VCCI, KCC, BSMI, RCM RoHS	FCC Class A, UL, CE, UKCA, CB, VCCI, BSMI, RCM RoHS, FIPS 140-2 [*]	FCC Class A, UL, CE, UKCA, CB, VCCI, KCC, BSMI, RCM RoHS
Standard Warranty	90-day hardware and software		

Hardware specifications and performance numbers are subject to change without notice, and may vary depending on configuration and environmental conditions. As for network interface, it's highly recommended to use A10 Networks qualified optics/transceivers to ensure network reliability and stability.

^{*1} Tested in single appliance SSLi deployment with maximum SSL option. Cipher "TLS_RSA_WITH_AES_256_CBC_SHA" with RSA 2K keys are used for RSA cases, "TLS_ECDHE_RSA_WITH_AES_128_CBC_SHA256" with EC P-256 and RSA 2K keys are used for PFS case. | ^{*2} With maximum SSL | ^{*3} With base model | ^{*4} Optional RPS available | ^{*5} 10Gbps speed only | ^{*6} Fixed SFP+ optical ports with dual rate (10GBASE-SR and 1000BASE-SX) | ^{*7} Hardware Bypass model comes equipped with the hardware TLS acceleration | [^] Certification in process | + FIPS model must be purchased | ^{*8} Doubled the capacity from ACOS 5.2.1-P7/ 6.0.1 onward | ^{*9} Not supported on non-S models | ^{*10} Modular license offering is available based on bandwidth needs | [^] Certification in process | + FIPS model must be purchased

Thunder CFW SPE Physical Appliance Specifications

Performance	Thunder 5845 CFW	Thunder 7445 CFW	Thunder 7655S CFW	Thunder 8665S CFW ⁷
Modular License	-	75/100/150/200/220 Gbps	-	-
Firewall Performance				
Throughput	100 Gbps	220 Gbps ⁶	370 Gbps	550 Gbps
Layer 4 CPS	3 Million	5 Million	8 Million	8.5 Million
Concurrent Sessions	128 Million	256 Million	768 Million ⁴	800 Million
FW Rules	64K / 128K ²	128K	128K	128K
Secure Web Gateway Performance^{1,2}				
SSLi Throughput	- ⁵	- ⁵	72 Gbps	- ⁷
SSLi CPS	- ⁵	- ⁵	RSA: 100K ECDHE: 70K	- ⁷
IPsec VPN Performance²				
IPsec Throughput	- ⁵	- ⁵	100 Gbps	- ⁷
IPsec Tunnels	- ⁵	- ⁵	100K	- ⁷
IKE Gateways	- ⁵	- ⁵	100K	- ⁷
Network Interfaces				
10/1GE Fiber (SFP+/SFP)	48	48	0	0
40GE Fiber (QSFP+)	0	0	0	0
100/40GE Fiber (QSFP28/QSFP+)	4 (QSFP28)	4 (QSFP28)	16 (QSFP28)	0
400GE Fiber (QSFP-DD)	0	0	0	12
Management Ports	Ethernet mgmt. port, RJ-45 console port, Lights out management			2 x Ethernet mgmt. port, RJ-45 console port
Hardware Specifications				
Processor	Intel Xeon 18-core	2 x Intel Xeon 18-core	2 x Intel Xeon 28-core	2 x Intel Xeon 36-core
Memory (ECC RAM)	64 GB / 128GB ²	128 GB	384 GB	512 GB
Storage	SSD	SSD	SSD	SSD
Hardware Acceleration	2 x FTA-4, SPE	3 x FTA-4, SPE	2 x FTA-5, SPE	3 x FTA-6, SPE
TLS/SSL Security Acceleration	Software	Software	Hardware	N/A
Dimensions (inches)	1.75 (H) x 17.5 (W) x 30 (D)	1.75 (H) x 17.5 (W) x 30 (D)	2.625 (H) x 17.5 (W) x 30 (D)	2.625 (H) x 17.5 (W) x 30 (D)
Rack Units (mountable)	1U	1U	1.5U	1.5U
Unit Weight	34.3 lbs	35.7 lbs	44.2 lbs	44.9 lbs
Power Supply (DC option available)	Dual 1500W RPS	Dual 1500W RPS	Dual 1500W RPS	Dual 2500W RPS
	80 Plus Platinum Efficiency, 100 - 240 VAC, 50 - 60 Hz			
Power Consumption (typical/max) ^{3,5}	585W / 921W	784W / 1,078W	1,121W / 1,300W	1,491W / 1,720W
Heat in BTU/hour (typical/max) ^{3,5}	1,997 / 3,143	2,676 / 3,679	3,826 / 4,436	5,088 / 5,869
Cooling Fan (front-to-back airflow)	Hot swap smart fans			
Operating Ranges	Temperature 0° - 40° C Humidity 5% - 95%			
Regulatory Certifications	FCC Class A, UL, CE, UKCA, CB, VCCI, BSMI, RCM RoHS	FCC Class A, UL, CE, UKCA, CB, VCCI, BSMI, RCM RoHS	FCC Class A, UL, CE, UKCA, CB, VCCI, KCC, BSMI, RCM RoHS, FIPS 140-2 ¹	FCC Class A, UL, ICES, CE, UKCA, CB, VCCI, RCM RoHS
Standard Warranty	90-day hardware and software			

Hardware specifications and performance numbers are subject to change without notice, and may vary depending on configuration and environmental conditions. As for network interface, it's highly recommended to use A10 Networks qualified optics/transceivers to ensure network reliability and stability.

^{*1} Tested in single appliance SSLi deployment with maximum SSL option. Cipher "TLS_RSA_WITH_AES_128_CBC_SHA256" with RSA 2K keys are used for RSA cases, "TLS_ECDHE_RSA_WITH_AES_128_CBC_SHA256" with EC P-256 and RSA 2K keys are used for ECDHE case. | ^{*2} With maximum SSL | ^{*3} With base model. Number varies by SSL model | ^{*4} Doubled the capacity from ACOS 5.2.1-P7/ 6.0.1 onward | ^{*5} Not supported on non-S models | ^{*6} Modular license offering is available based on bandwidth needs | ^{*7} Thunder 8665S is currently supported with CGN and Gi-FW use cases. | [^] Certification in process | ⁺ FIPS model must be purchased

Thunder CFW Software Appliance Specifications

vThunder CFW										
Supported Hypervisors	VMware ESXi (VMXNET3, SR-IOV, PCI Passthrough), KVM QEMU (VirtIO, OvS with DPDK, SR-IOV, PCI Passthrough), Microsoft Hyper-V ³									
Hardware Requirements	See installation guide									
Standard Warranty	90-day software									
Bandwidth Licenses	Lab	200 Mbps	1 Gbps	4 Gbps	8 Gbps	10 Gbps	20 Gbps	40 Gbps	100 Gbps	FlexPool
VMware ESXi	●	●	●	●	●	●	● ^{*1}	● ^{*1, *2}	● ^{*2}	●
KVM	●	●	●	●	●	●	● ^{*1}	● ^{*1, *2}	● ^{*2}	●
Microsoft Hyper-V ³	●	●	●	●	●					●
Feature basis Throughput Guideline	ADC/CGN/FW: 200 Mbps-100 Gbps IPsec/SSL Insight (SWG) without hardware SSL/TLS acceleration: 200 Mbps – 8 Gbps									

*1 SR-IOV | *2 PCI Passthrough | *3 Hyper-V is supported in ACOS 4.x and 5.x release. 8 Gbps license is not recommended.

Thunder CFW Containers*	
Image Format	Docker
Operating System	Reference operating system: - Ubuntu 16.04.3 LTS (Xenial Xerus) - RedHat Enterprise Linux version 7.6
System Requirements	Minimum requirement: - 1 or more data interface - 1 vCPU and 4GB memory
Licenses	BYOL bandwidth license FlexPool license
Performance Reference**	Maximum throughput on a single Thunder container (24 vCPUs, shared polling mode off) 1510B: 180 Gbps 512B: 103 Gbps IMIX : 75 Gbps
Standard Warranty	90-day software

* Carrier-class firewall along with CGNAT and data-center firewall with ADC are the common use cases. SSL Insight (SWG) and IPsec are not adequate use cases.

** Supermicro 7049GP-TRT with Intel Xeon Platinum 8160 CPU @ 2.10GHz and 2x NVIDIA Mellanox Connect X-5 NICs. Tested with UDP traffic for CGNAT use case.

Detailed Feature List

Features may vary by appliance.

Carrier Class Firewall

Firewall

- Stateful Layer 4 network firewall
- L7 application-aware firewall and visibility**
- L4-L7 services consolidation
- Gi/SGi firewall
- GTP firewall with granular SCTP filtering
- Application layer gateways (DNS, ESP, FTP, ICMP, PPTP, RTSP, SIP, TFTP)

DDoS Protection

- Integrated DDoS protection for NAT IP pools
- IP anomaly detection
- DDoS protection for Gi/SGi firewall

IPv4 Preservation (CGNAT)

- Carrier-grade NAT (CGN/CGNAT), Large-scale NAT (LSN), NAT444, NAT44

IPv6 Migration

- Dual-stack support, full-native IPv6 management and features
- SLB-PT (protocol translation), SLB-64 (IPv4->IPv6, IPv6->IPv4)
- NAT64/DNS64, NAT46, DS-Lite, 6rd, LW4o6, MAP-T, MAP-E

Visibility and Analytics with Harmony Controller

- CGNAT
 - Subscriber session insights
 - Session opening and closing rates
 - TopN flow consuming subscribers
 - TopN bandwidth consuming subscribers
 - Subscriber user quota alerts
 - CGN resource tracking
 - Mapping distribution per protocol and per technology
 - NAT IP pool utilization
 - Session distribution per NAT technology
- Firewall
 - Firewall rule performance and rule distribution by protocol
 - Top firewall rules by state
 - GTP traffic insights, roam-in/out view and policy violation analytics
 - Comprehensive transduction log with source/destination IP, port, protocol, application, application category, and firewall actions for better visibility and faster troubleshooting
- Application
 - Application distribution by category
 - Top destination IP by application distribution
 - Bytes consumed by application category

Secure Web Gateway (SWG)

SSL Insight

- High-performance SSL decryption and encryption as a forward proxy
- Internet content adaptation protocol (ICAP) support for data loss prevention
- Dynamic port decryption to detect and intercept SSL or TLS traffic regardless of TCP port number
- Forward proxy failsafe to bypass traffic when there is a handshake failure
- SSL Insight bypass based on hostname; bypass list scales up to 1 million server name indication (SNI) values
- Multi-bypass list support
- Decryption of HTTPS, STARTTLS, SMTP, XMPP
- Client certificate detection and optional bypass
- Untrusted certificate handling using the online certificate status protocol (OCSP)
- TLS alert logging to log flow information from SSL Insight events
- SSL session ID reuse
- Firewall load-balancing (FWLB)

URL Filtering**

- URL classification service powered by Webroot to selectively bypass trusted websites for SSL decryption
- Optional monitoring and blocking of malicious or undesirable websites

Application-aware Firewall**

- Recognition of thousands protocol signatures with identification of service types within applications
- Support custom rules that run real-time

IP Threat Intelligence**

- Prevents malicious traffic from entering your network, based on customizable risk score and tolerance

Threat Investigator**

- Rich and contextual analytics for object under investigation

Operation Modes

- Transparent forward proxy
- Explicit forward proxy
- Proxy chaining

Centralized Management and Analytics with Harmony Controller

- Device and configuration management across multiple sites
- Deployment wizard with guided configuration
- Centralized security policy management and enforcement
- Rich TLS/SSL traffic and decryption analytics for traffic insight, application insight, URL insight, source and destination insight and more
- Threat investigator view
- Session log drill-down
- Troubleshooting tools

Detailed Feature List (Cont.)

Data Center Firewall

Firewall

- Stateful L4 network firewall
- Application layer gateways (DNS, ESP, FTP, ICMP, PPTP, RTSP, SIP, TFTP)

DDoS Protection

- Flood attack protection: SYN cookies, TCP/UDP/ICMP flood protection, DNS/HTTP flood protection
- Protocol attack protection: invalid packets, anomalous TCP flag combinations, packet size validation (ping of death)
- Resource attack protection: slowloris, slow POST, sockstress, fragmentation
- Rate-limiting: IP-based connection, HTTP, DNS request, DNS query, ICMP rate-limiting

Application Access Management (AAM)

- Authentication methods: HTTP Basic, NTLM over HTTP, form-based, OCSP, TDS SQL Logon and SAML
- Authentication servers: LDAP, Active Directory, RADIUS, OCSP Responder, NTLM, Kerberos, RSA Secure ID, Entrust IdentityGuard and SAML Identity Provider (IdP)
- Authentication relay: Kerberos, form-based, LDAP, WS-Federation, and Microsoft SharePoint and Outlook Web Access
- Extensive logging for audit

A10 Next-Gen WAF (powered by Fastly)**

- Comprehensive OWASP top attacks protection
- Account takeover (ATO) protection
- Advanced rate limiting
- Network learning exchange
- Virtual patching for CVEs
- Streamlined management and extensive visibility on application attacks and anomalies
- Compliance
- Explicit proxy deployment support

ADC

- Advanced L4/L7 server load-balancing
 - Full HTTP proxy, Fast HTTP, HTTP/2, FIX, SIP, RADIUS, FTP, TCP, UDP and more
 - High-performance, template-based L7 switching with header/URL/domain manipulation
 - Comprehensive L7 application persistence support
- DNS load balancing
 - Layer 4 (TCP, UDP) and Layer 7 (DNS-UDP, DNS-TCP)
- Global Server Load Balancing (GSLB)
- Comprehensive IPv4/IPv6 support
- aFlex® TCL-based scripting: deep packet inspection and transformation for customizable, application-aware switching
- HTTP acceleration: HTTP connection multiplexing (TCP connection reuse),
- RAM caching, HTTP compression
- SSL acceleration: Hardware SSL, TLS 1.2, TLS 1.3 support, Elliptic Curve Diffie-Hellman Exchange (ECDHE) and other PFS ciphers
- ACME client support for automating TLS certificate renewal with Let's Encrypt, Sectigo and else

DNS Security

- DNS over HTTPS (DoH), DNS over TLS (DoT)
- Recursive DNS
- DNS cache
- DNS firewall/RPZ
- DNS application firewall (DAF)
- DNSSEC

IPsec VPN

- Route-based VPN
- Policy-based VPN
- Keying methods: IKEv1, IKEv2, IKE-CP
- Authentication methods: RSA signature, pre-shared key, public key infrastructure (PKI)
- Key exchange Diffie-Hellman groups: 1, 2, 5, 14, 15, 16, 18
- Encryption algorithms: DES, 3DES, AES-128, AES-192, AES-256
- Data integrity: MD5, SHA1 and SHA-256
- OSPF, BGP and bidirectional forwarding detection (BFD) over IPsec tunnel
- IPv4 and IPv6 support
- Equal cost multipath (ECMP) support
- NAT traversal
- IPsec logging with log filter
- Certificate management protocol version 2 (CMPv2)
- Perfect forward secrecy (PFS) support
- Life bytes and time rekey
- PKI support with simple certificate enrollment protocol (SCEP), online certificate status protocol (OCSP) and certificate revocation list (CRL) distribution points

Common Features

A10 Threat Intelligence Service**

- Dynamically updated threat intelligence feed
- Millions of IP addresses that are vulnerable and weaponized for DDoS attacks, including IoT DDoS botnets, DDoS drones, exploitable open reflectors

Scalable, High-performance Platform

- Advanced Core Operating System (ACOS)
 - Multi-core CPU support
 - Linear application scaling with scalable symmetrical multi-processing (SSMP) architecture
 - ACOS on data plane
- Linux on control plane
- IPv6 feature parity
- Flexible traffic acceleration (FTA) for scalable flow distribution, common attack mitigation
 - Hardware FTA utilizing FPGAs
- Scale-out cluster

Networking

- Integrated Layer 2/Layer 3
- Transparent mode/gateway mode
- Virtual wire interface support
- Routing – static routes, IS-IS (v4/v6), RIPv2/ng, OSPF v2/v3, BGP4+
- L2 protocols (STP, RSTP, MSTP)
- VLAN (802.1Q)
- Link aggregation (802.1AX), LACP
- Access control lists (ACLs)
- Traditional IPv4 NAT/NAPT
- IPv6 NAPT
- Jumbo frame support*
- Hardware-accelerated VXLAN*
- NVGRE

Detailed Feature List (Cont.)

Common Features (Cont.)

Management

- Dedicated on-box management interface (GUI, CLI, SSH, Telnet)
- Web-based AppCentric templates (ACT) intuitive guided configuration tool
- SNMP, syslog, email alerts, NetFlow v9 and v10 (IPFIX), sFlow
- RESTful API (aXAPI)
- LDAP, TACACS+, RADIUS support
- Configurable control CPUs
- Interoperable with A10 Harmony Controller for centralized management, configuration and analytics
- Plug-in available for VMware vRealize Orchestrator deployments

Virtualization

- Thunder virtual appliance for VMware vSphere ESXi, Microsoft Hyper-V and KVM
- Thunder ADC for Amazon Web Services (AWS), Microsoft Azure, Google Cloud and Oracle Cloud
- Thunder ADC for Bare Metal
- Thunder ADC for containers
- Networking acceleration (SR-IOV, DPDK) and management integration
- A10 Thunder on Dell Technologies OEM solution bundle

Extensibility

- aVCS (virtual chassis system)
- Multi-tenancy with application delivery partitions (ADP) with L3-7 separation
- L3 virtualization

DevOps Tools and Integration

- Ansible modules and playbooks
- Terraform Thunder provider
- HashiCorp's Consul and Network Infrastructure Automation (NIA) integration
- Thunder Kubernetes Connector (TKC)
- Microsoft Azure ARM templates
- AWS CloudFormation templates
- OpenStack Octavia driver
- Cloud-init support for auto-configuration on
 - OpenStack
 - OCI
 - AWS
 - Azure
- Prometheus integration for visibility and analytics monitoring
- Automatic certificate renewal with Sectigo, Let's Encrypt, Venafi and more
- Thunder Observability Agent (TOA) for publishing Thunder metrics and logs to
 - AWS CloudWatch
 - Azure Application Insights / Log Analytics
 - VMware vRealize Operations (vROps) / Log Insights (vRLI)

Carrier-grade Hardware*

- Advanced hardware architecture
- Hot-swap redundant power supplies (AC and DC)
- Smart fans (hot swap)
- Solid-state drive (SSD)
- Tamper detection
- Lights out management (LOM/IPMI)
- 25GE, 40GE, 100GE and 400GE
- High-performance security processor option

Flexible Licensing

- Modular licensing for Thunder hardware* allowing "pay-as-you-grow" model and capacity upgrade
- Fixed bandwidth licensing for Thunder running in any software form factor
- FlexPool: portable and flexible capacity pooled licensing for software Thunder running across any private and public clouds

Security and Capability Assurance Certifications*

- ICSA Labs certification
- Common Criteria EAL 2+
- FIPS 140-2 Level 2
- Joint Interoperability Test Command (JITC)
- Network Equipment Building System (NEBS) compliance

* Features and certifications may vary by appliance.

** Additional subscription or service is required.

Learn More

About A10 Networks

Contact Us

[A10networks.com/contact](https://a10networks.com/contact)

©2024 A10 Networks, Inc. All rights reserved. A10 Networks, the A10 Networks logo, ACOS, Thunder, Harmony and SSL Insight are trademarks or registered trademarks of A10 Networks, Inc. in the United States and other countries. All other trademarks are property of their respective owners. A10 Networks assumes no responsibility for any inaccuracies in this document. A10 Networks reserves the right to change, modify, transfer, or otherwise revise this publication without notice. For the full list of trademarks, visit: [A10networks.com/a10trademarks](https://a10networks.com/a10trademarks).

Part Number: A10-DS-15112-EN-25 Oct 2024